



August 30, 2007

In Reply Refer To: HSSD/CC-100

Archived

Dr. Hayes Ross
Texas Transportation Institute
3135 TAMU
College Station, TX 778433-3135

For

Dear Dr. Ross:

In your letter of May 16, 2007, you requested the Federal Highway Administration's (FHWA) acceptance of a 31-inch (787 mm) high Slotted Rail Terminal (SRT-31) as a National Cooperative Highway Research Program (NCHRP) Report 350 Test Level 3 (TL-3) system. To support this request, you provided the Texas Transportation Institute (TTI) reports dated May 2007, entitled "NCHRP Report 350 Test 3-30 of the SRT-31" and "NCHRP Report 350 Test 3-35 of the SRT-31". You also provided earlier completed TTI reports on crash testing of a new terminal for cable/wire rope guardrail and on testing of T-31 W-beam guardrail, test videos, and electronic copies of the drawings.

Requirements

Barrier end treatments should meet the guidelines contained in the NCHRP Report 350, "Recommended Procedures for the Safety Performance Evaluation of Highway Features". FHWA Memorandum "ACTION: Identifying Acceptable Highway Safety Features" of July 25, 1997 provides further guidance on crash testing requirements of longitudinal barriers.

Product description

The SRT-31 was developed to be used for terminating 31-inch (787 mm) high strong post W-Beam guardrail systems including 31-inch (787 mm) high Midwest Guardrail System (MGS) with blockouts and 31-inch (787 mm) high T-31 W-beam Guardrail System without blockouts. The design of SRT-31 is based on the previously accepted Slotted Rail Terminals (FHWA acceptance letter CC-72 of December 18, 2000) with the following changes:

1. It is an all-steel terminal.
2. The guardrail is raised to 31 inches (787 mm) throughout the terminal length.
3. No blockouts are used between rail and post at post locations 1 through 6.
4. Upper part of Cable Release Post (CRP) is modified to accommodate 31-inch (787 mm) high guardrail at post 1.
5. Two 12.5 ft (3.8 m) slotted W-beam panels are used between posts 1 and 5, as is currently used in the 27-inch (686 mm) high terminal.



6. Special 9.375 ft (2.86 m) long W-beam panel is used beginning at post 5. This creates mid-span splices between posts 6 and 7, and beyond. If SRT-31 is used with 31-inch (787 mm) systems where W-beam splices are located at posts, a standard 150-inch (3810 mm) long panel is placed between posts 5 and 7.
7. Steel yielding terminal posts (SYTP) are used at post positions 2 through 6.
8. W-beam is disconnected at posts 2 through 5.
9. W-beam backup plates are used at post positions 2 and 4.
10. Shelf angle is used at post position 2 to provide rail support for vertical forces that occur during redirection tests.
11. Standard W6 x 8.5 (W150 x 12.6) or W6 x 9 (W150 x 14) line post is used at post position 7.

Design details of the SRT-31 are given in Enclosure 1. It should be noted that in the process of development of the described design you initially designed a system which used 12-inch (305 mm) blockouts and no shelf angle at post location 2. With the acceptance of 31-inch (787 mm) high T-31 W-beam Guardrail System without blockouts (FHWA acceptance letter B-140 of November 3, 2005) you decided to develop the described above 31-inch (787 mm) SRT system with no blocks as a more cost effective design.

Test article installations

Details of the SRT-31 installation as used in test 3-35 are provided in Enclosure 2. Essentially the same installation was used in test 3-30, except for the changes in the SRT-31 itself, as described above.

Testing

The NCHRP Report 350 requires that in order for barrier end treatments to meet test level 3 (TL-3) criteria they must successfully pass tests 3-30, 3-31, 3-32, 3-33, 3-34, 3-35 and 3-39. You conducted only test 3-30 on the SRT-31 system with blockouts and test 3-35 on the final design of the SRT-31 system (with no blocks) and provided explanations on why in your opinion the rest of the tests can be waived. Upon review of your explanations and crash test performance demonstrated in conducted tests we are willing to agree with your assumptions. Specifically, we agree that:

- Test 3-30 (820C, end-on, 0 degrees, offset) conducted on initial version of the SRT-31 system (with blockouts at posts 3 through 6 and without shelf angle at post position 2) is more critical than the same test on the final design because in the impact with the final design of the SRT-31 system the vehicle would most likely engage fewer posts and will experience lower turning moment as longitudinal forces will be applied closer to the centerline of the vehicle front. As such, the vehicle will yaw less clockwise and will thus track through the system better than in impacts with the initial version of the SRT-31 system.
- Test 3-31 (2000P, end-on, 0 degrees, centered) on the SRT-31 system is less critical than test 3-31 conducted previously on a 27-inch (686 mm) high SRT system, with a straight flare, a 4-ft (1.2 m) flare offset, 6 x 8 inch (152 x 203 mm) blocks at post locations 3 and

beyond and wood CRT posts at post locations 3 through 5 (FHWA acceptance letter CC-72 of December 18, 2000). In test 3-31 with SRT-31 the vehicle will engage fewer and more forgiving posts as SYTP posts at post locations 2 through 6 in the SRT-31 system have less resistance to impact than CRT posts. Further, as opposed to the previous design, the rail is not attached to the posts at post locations 3 and beyond and therefore the detached posts at locations 2 through 5 will bend and lay down at a lower force.

- Tests 3-32 (820C, end-on, 15 degrees, centered) and 3-33 (2000P, end-on, 15 degrees, centered) can be considered less severe than tests 3-30 and 3-31 as SRT-31 will gate upon impacts in this tests.
- Test 3-39 (2000P, reverse hit, 20 degrees) will be a non-discerning test for the straight flared SRT-31 system as the impact angle of the 2000P relative to the rail will occur at 14 degrees (20 degrees minus 6 degrees flare rate) and therefore will be of relatively low severity. Some additional factors further justify the conclusion of the redundancy of test 3-39, e.g., SYTP posts are designed to yield from either the downstream and reverse direction, and detachment of SYTP posts from the W-beam at locations 2 through 5 will allow them to easily bend and lay down when impacted. The post bolt hole in the rail at post location 1 is slotted upstream to the free edge of the rail, so that in a reverse hit the rail offers no resistance to the release of the CRP at post location 1. Also, CRP releases for impacts in the reverse direction as shown in pendulum tests and also in crash testing of cable guardrail systems.

Your justification of the redundancy of test 3-34 (820C, redirection, 15 degrees at CIP of gating part of the device) was based on the comparison of it to Test 3-10 (820C, redirection, 20 degrees) conducted on the T-31 W-beam Guardrail System. Upon review we are willing to agree that test 3-34 at a 15 degree impact with post 2 of the SRT-31 system would be very similar in impact severity to test 3-10 at a 20 degree impact angle with the T-31 system. Also, the detachment of rail in SRT-31 system at post positions 2 through 5 resulting in lower impact resistance of the SYLP posts will further improve vehicular performance in test 3-34 of the SRT-31 system in comparison to test 3-10 of the T-31 system. Further, because test 3-34 was successfully conducted on the original SRT designs which had a more critical parabolic flare, we are willing to agree that SRT-31 would perform better in test 3-34 than the original design.

According to the information you provided, SRT-31 performed successfully in both tests 3-30 and 3-35. The summaries of tests results are presented in Enclosure 3.

In test 3-30 SRT-31 slowed the 820C vehicle as the vehicle gated behind the terminal in a controlled manner subsequently coming to rest on the back side of the terminal. The vehicle remained upright during and after the collision event. No penetration of the occupant compartment occurred and maximum occupant compartment deformation was 0.7 inch (18 mm) in the driver's side door panel area near hip height. Occupant risk factors were within the preferred limits.

In test 3-35 SRT-31 contained and redirected the pickup truck. The rail element separated from all posts of the system, but the anchor cable maintained attachment keeping the rail adjacent to the posts. No occupant compartment deformation occurred. The pickup truck remained upright

during and after the collision event. No occupant compartment deformation occurred, and occupant risk factors were within the preferred limits. Based on the results of test 3-35, the beginning of length-of-need of the SRT-31 is at post 3, approximately 12.5 ft (3.8 m) from the end.

In summary we agree that 31-inch (787 mm) high Slotted Rail Terminal (SRT-31) as described above meets the appropriate evaluation criteria for the NCHRP 350 TL-3 devices and may be used with 31-inch high strong post W-Beam guardrail systems including 31-inch (787 mm) high Midwest Guardrail System (MGS) with blockouts, the 31-inch (787 mm) high T-31 W-beam Guardrail system without blockouts, and the 31-inch (787 mm) high Gregory Mini Spacer (GMS) Guardrail System without blockouts at all appropriate locations on the National Highway System (NHS) when selected by the contracting authority, subject to the provisions of Title 23, Code of Federal Regulations, Section 635.411, as they pertain to proprietary products. Please note also that this acceptance is based on the reported crash performance of your posts and is not meant to address their installation, maintenance or repair characteristics.

Standard provisions

Please note the following standard provisions that apply to the FHWA letters of acceptance:

- This acceptance is limited to the crashworthiness characteristics of the devices and does not cover their structural features, nor conformity with the Manual on Uniform Traffic Control Devices.
- Any changes that may adversely influence the crashworthiness of the device will require a new acceptance letter.
- Should the FHWA discover that the qualification testing was flawed, that in-service performance reveals unacceptable safety problems, or that the device being marketed is significantly different from the version that was crash tested, it reserves the right to modify or revoke its acceptance.
- You will be expected to supply potential users with sufficient information on design and installation requirements to ensure proper performance.
- You will be expected to certify to potential users that the hardware furnished has essentially the same chemistry, mechanical properties, and geometry as that submitted for acceptance, and that they will meet the crashworthiness requirements of the FHWA and the NCHRP Report 350.
- To prevent misunderstanding by others, this letter of acceptance, designated as number CC-100 shall not be reproduced except in full. This letter, and the test documentation upon which this letter is based, is public information. All such letters and documentation may be reviewed at our office upon request.
- The Slotted Rail Terminal (SRT-31) is a patented product and considered proprietary. If proprietary devices are specified by a highway agency for use on Federal-aid projects, except exempt, non-NHS projects, they: (a) must be supplied through competitive bidding with equally suitable unpatented items; (b) the highway agency must certify that they are essential for synchronization with the existing highway facilities or that no

equally suitable alternative exists; or (c) they must be used for research or for a distinctive type of construction on relatively short sections of road for experimental purposes. Our regulations concerning proprietary products are contained in Title 23, Code of Federal Regulations, Section 635.411.

This acceptance letter shall not be construed as authorization or consent by the FHWA to use, manufacture, or sell any patented device for which the applicant is not the patent holder. The acceptance letter is limited to the crashworthiness characteristics of the candidate device, and the FHWA is neither prepared nor required to become involved in issues concerning patent law. Patent issues, if any, are to be resolved by the applicant.

Sincerely yours,



George E. Rice, Jr.
Acting Director, Office of Safety Design
Office of Safety

Enclosures

Archived
For
Research
and
Historical
Purposes
Only

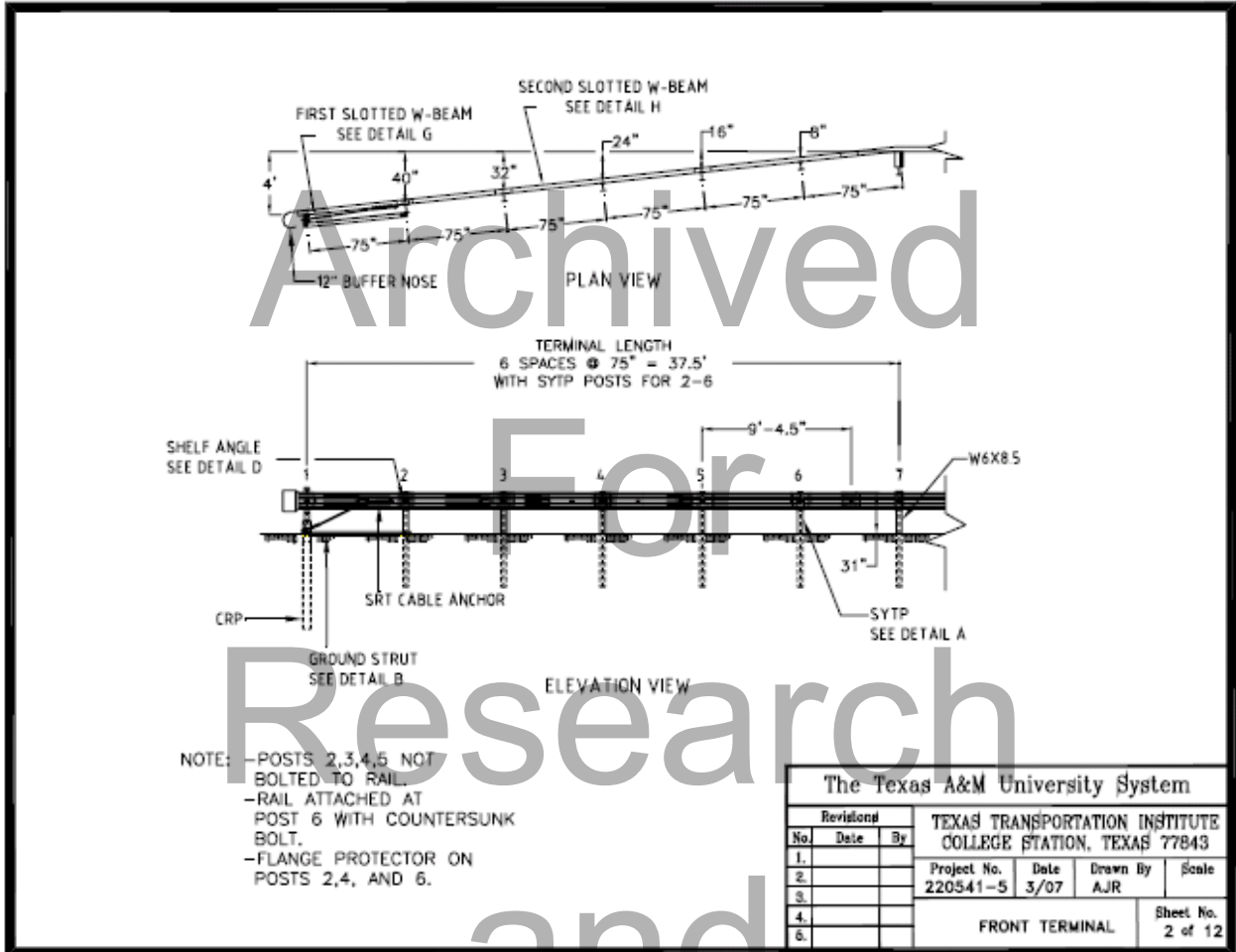

NOTE: -POSTS 2,3,4,5 NOT BOLTED TO RAIL.
-RAIL ATTACHED AT POST 6 WITH COUNTERSUNK BOLT.
-FLANGE PROTECTOR ON POSTS 2,4, AND 6.

The Texas A&M University System			
Revisions		TEXAS TRANSPORTATION INSTITUTE	
No.	Date	COLLEGE STATION, TEXAS 77843	
1.		Project No.	Date
2.		220541-5	3/07
3.		Drawn By	Scale
4.		AJR	
5.		FRONT TERMINAL	
6.		Sheet No. 2 of 12	

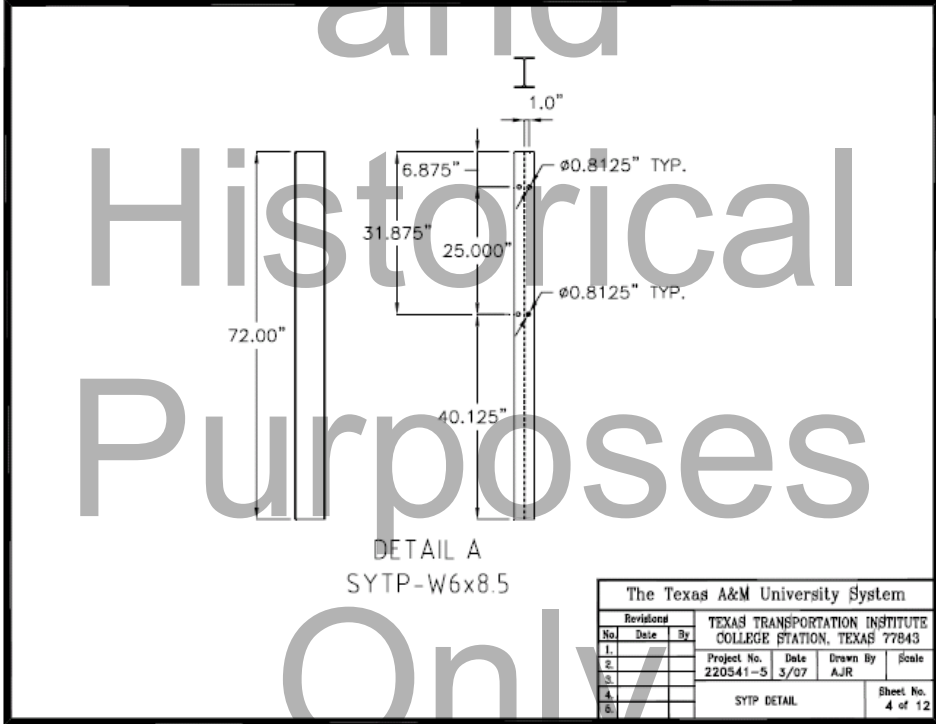

The Texas A&M University System			
Revisions		TEXAS TRANSPORTATION INSTITUTE	
No.	Date	COLLEGE STATION, TEXAS 77843	
1.		Project No.	Date
2.		220541-5	3/07
3.		Drawn By	Scale
4.		AJR	
5.		SYTP DETAIL	
6.		Sheet No. 4 of 12	

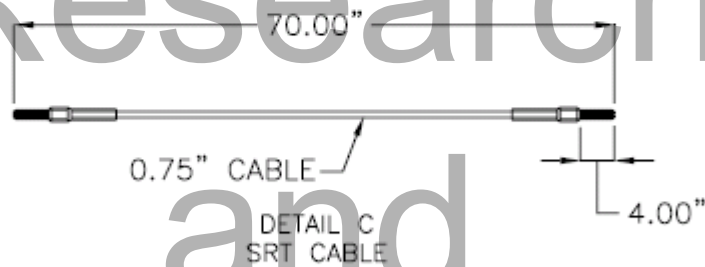
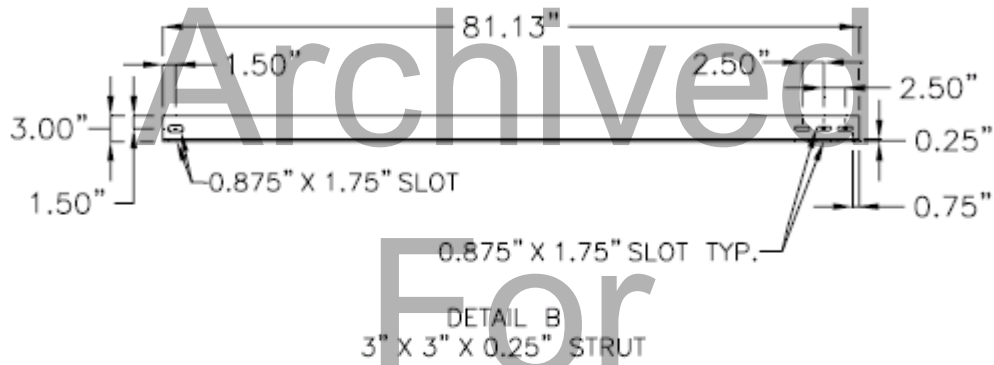

The Texas A&M University System				
Revisions			TEXAS TRANSPORTATION INSTITUTE COLLEGE STATION, TEXAS 77843	
No.	Date	By	Project No.	Date
1.			220541-5	3/07
2.				
3.				
4.			CABLE ANCHOR AND STRUT	Sheet No.
5.			DETAIL	5 of 12

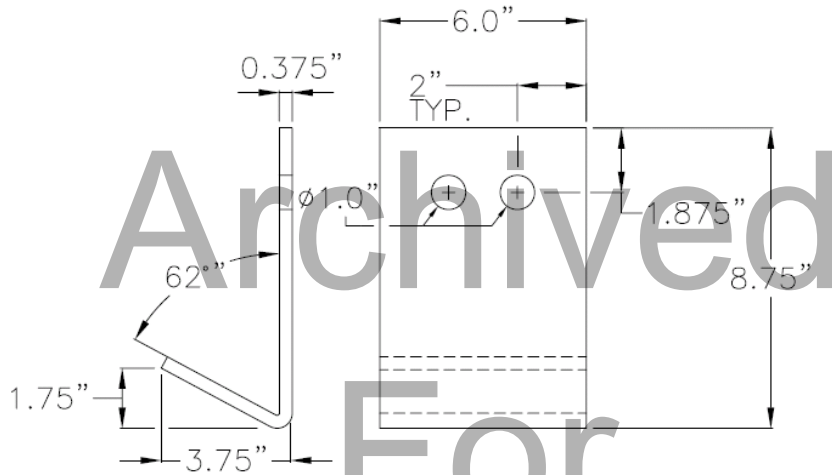

DETAIL D
A-36 STEEL

The Texas A&M University System			
Revisions		TEXAS TRANSPORTATION INSTITUTE COLLEGE STATION, TEXAS 77843	
No.	Date	By	Scale
1.			
2.			
3.			
4.			
5.			
Project No. 220541-5			Date 3/07
Drawn By AJR			Scale
W-BEAM GUARDRAIL			Sheet No. 1 of 1

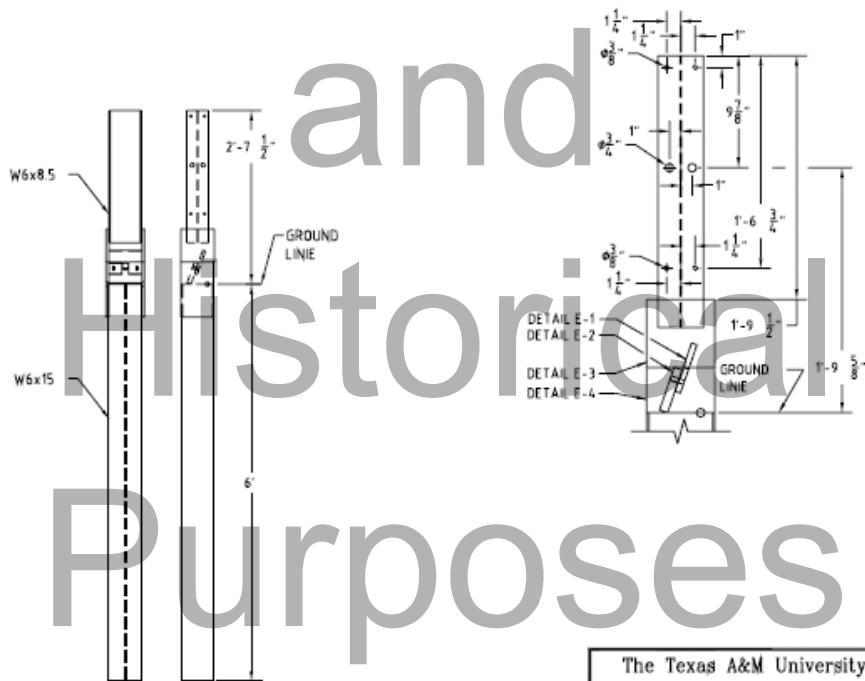

DETAIL E

The Texas A&M University System			
Revisions		TEXAS TRANSPORTATION INSTITUTE COLLEGE STATION, TEXAS 77843	
No.	Date	By	Scale
1.			
2.			
3.			
4.			
5.			
Project No. 220541-5		Date 3/07	Scale
Drawn By AJR		Sheet No. 6 of 12	
CRP POST			

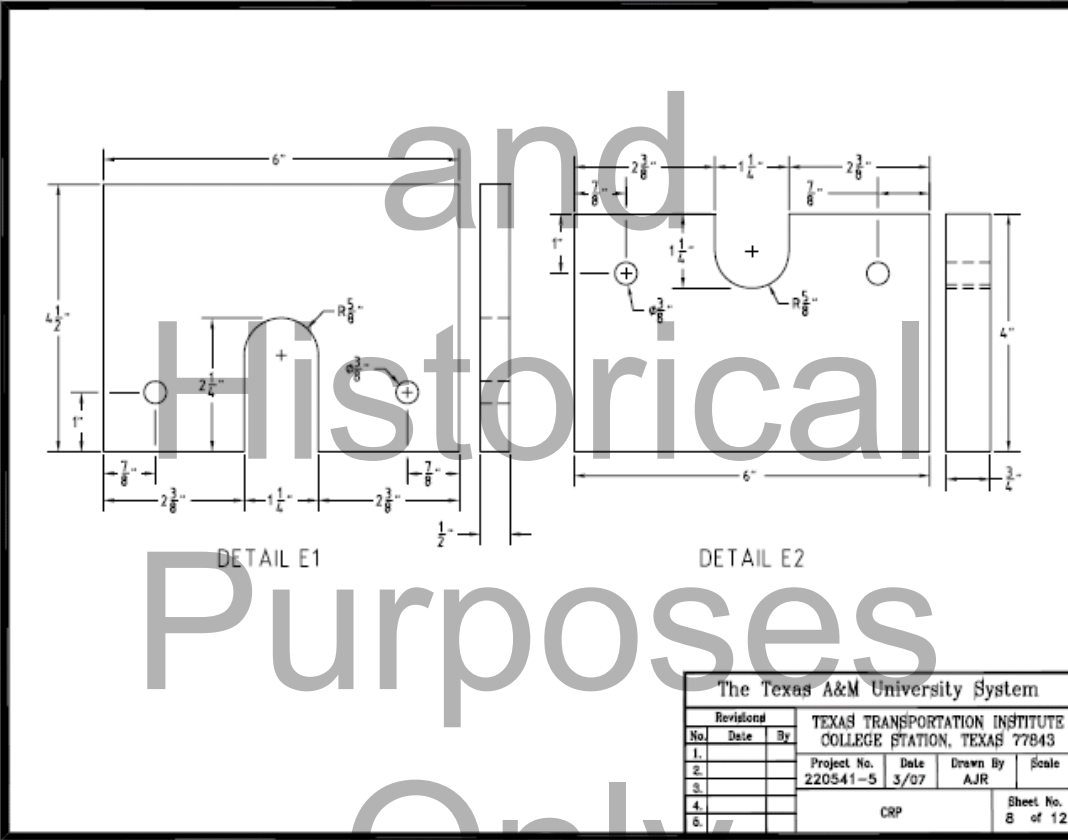
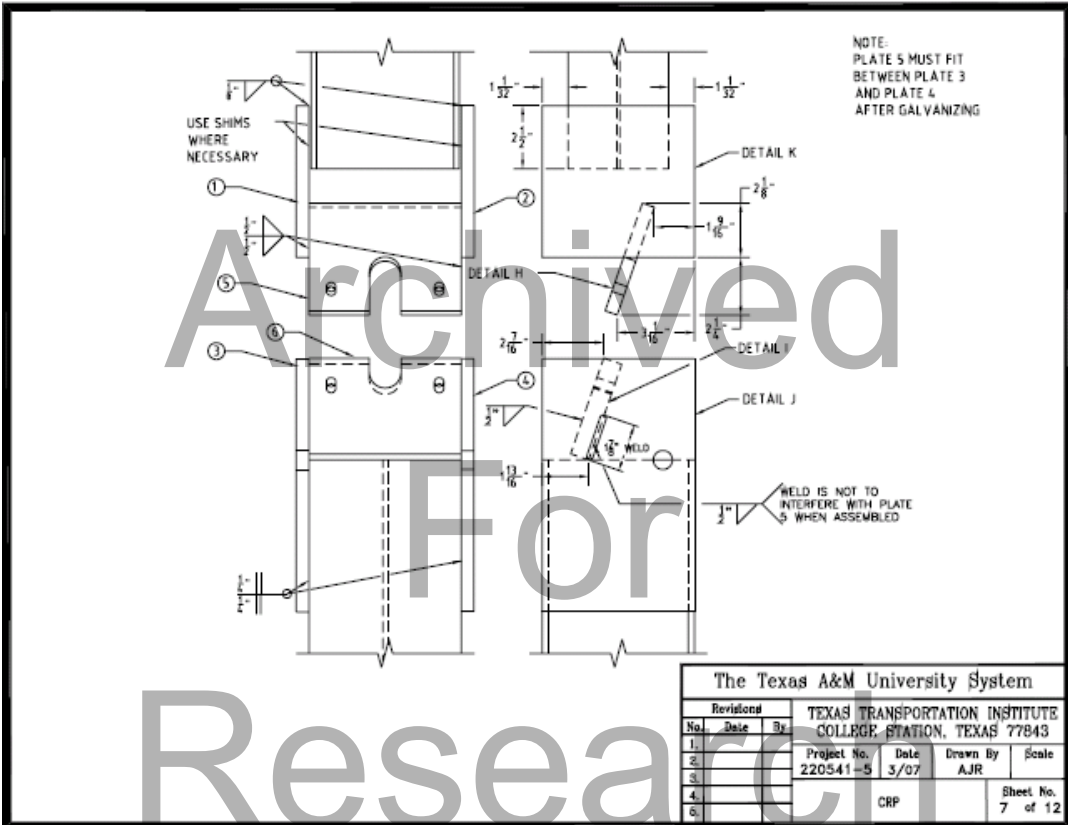

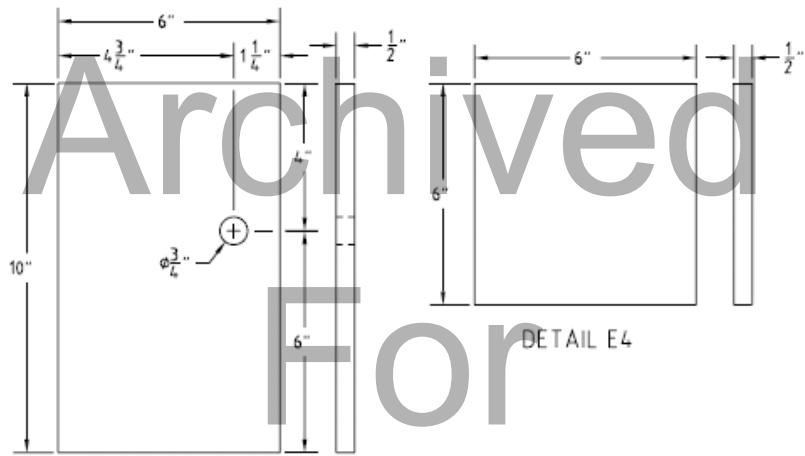

DETAIL E3

DETAIL E4

The Texas A&M University System					
Revisions			TEXAS TRANSPORTATION INSTITUTE COLLEGE STATION, TEXAS 77843		
No.	Date	By	Project No.	Date	Drawn By
1.			220541-5	3/07	AJR
2.					
3.					
4.					
5.			CRP		
					Sheet No. 9 of 12

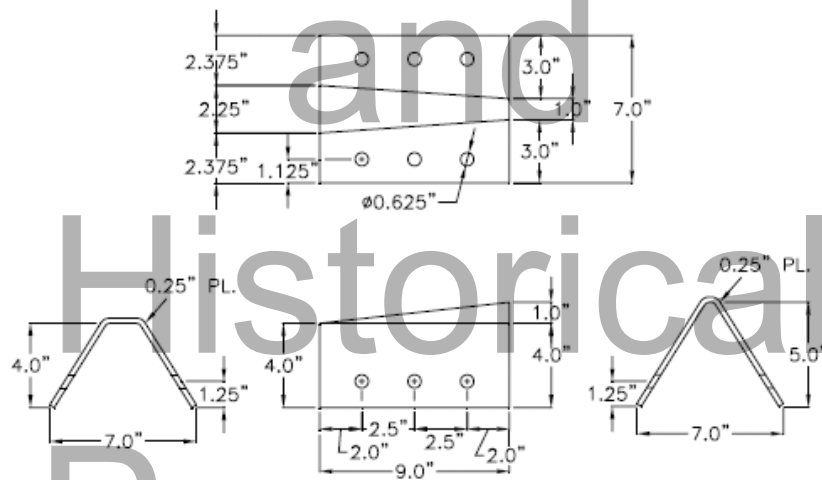

W-BEAM SLOTGUARD
DETAIL F

The Texas A&M University System					
Revisions			TEXAS TRANSPORTATION INSTITUTE COLLEGE STATION, TEXAS 77843		
No.	Date	By	Project No.	Date	Drawn By
1.			220541-S	3/07	AJR
2.					
3.					
4.					
5.			SLOTGUARD DETAILS		
					Sheet No. 10 of 12

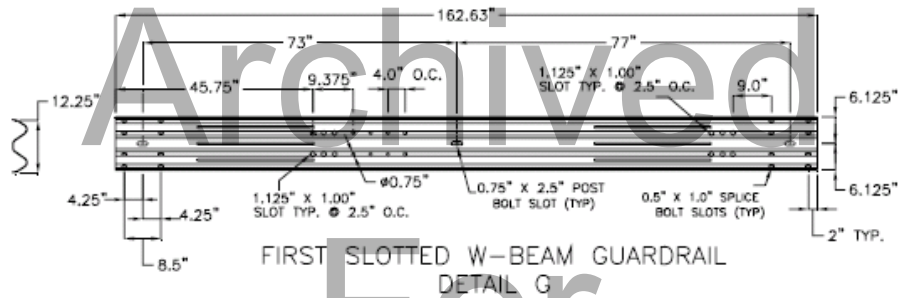

The Texas A&M University System					
Revisions			TEXAS TRANSPORTATION INSTITUTE COLLEGE STATION, TEXAS 77843		
No.	Date	By	Project No.	Date	Drawn By
1.			220541-5	3/07	AJR
2.					
3.					
4.					
5.					
W-BEAM GUARDRAIL					Sheet No. 11 of 12

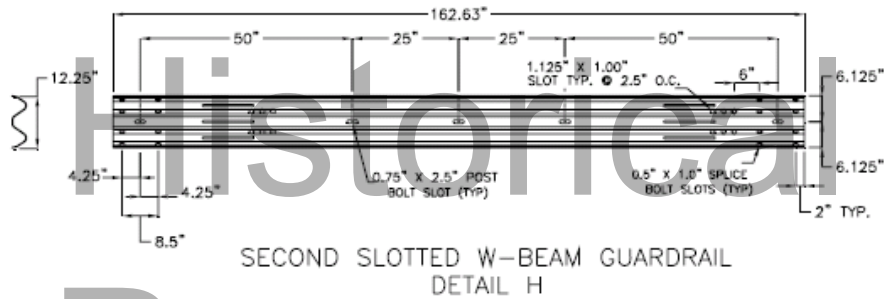

The Texas A&M University System					
Revisions			TEXAS TRANSPORTATION INSTITUTE COLLEGE STATION, TEXAS 77843		
No.	Date	By	Project No.	Date	Drawn By
1.			220541-5	3/07	AJR
2.					
3.					
4.					
5.					
W-BEAM GUARDRAIL					Sheet No. 12 of 12

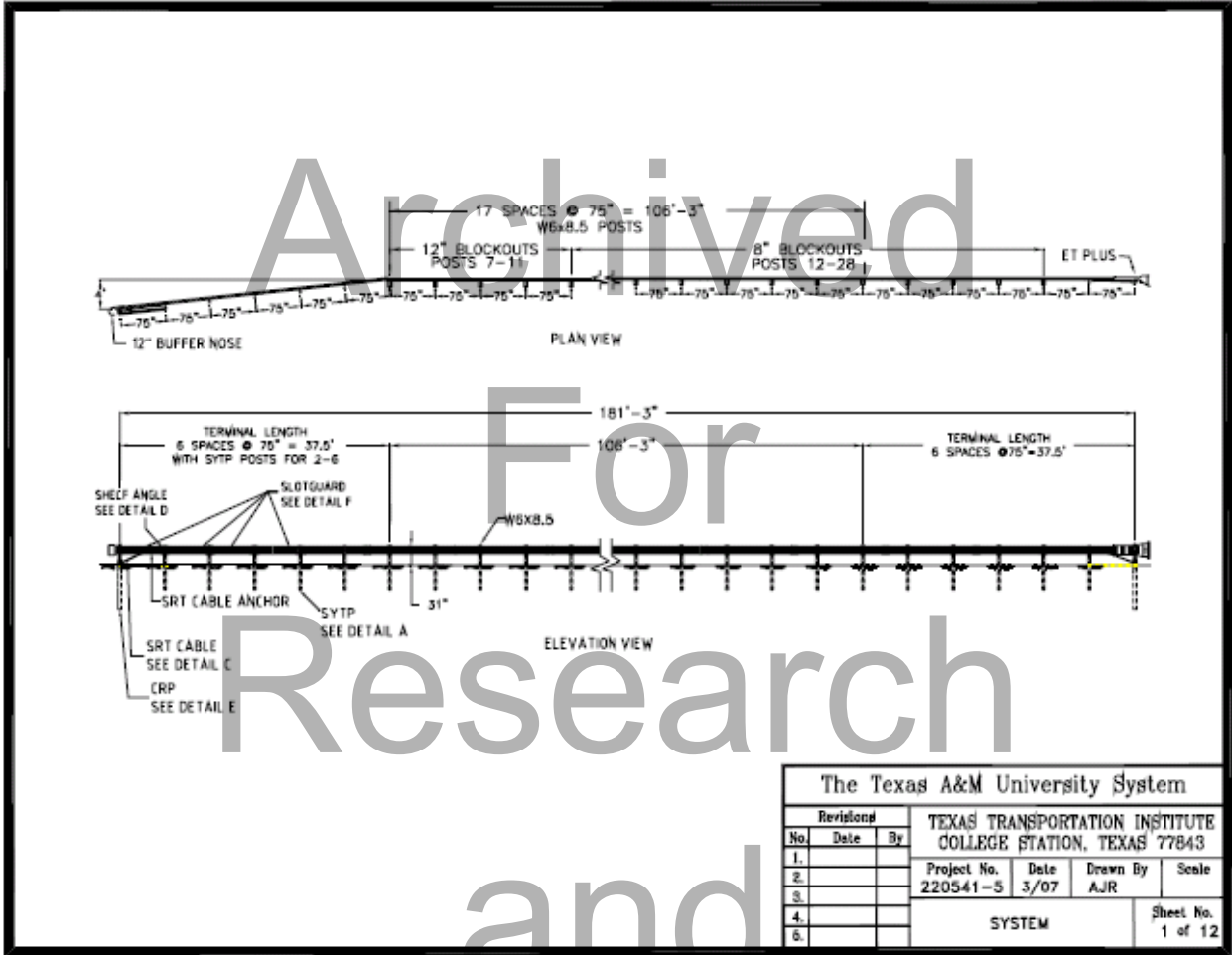

The Texas A&M University System					
Revisions			TEXAS TRANSPORTATION INSTITUTE COLLEGE STATION, TEXAS 77843		
No.	Date	By	Project No.	Date	Drawn By
1.			220541-5	3/07	AJR
2.					
3.					
4.					
5.					
6.					
SYSTEM					Sheet No. 1 of 12

Historical
Purposes
Only

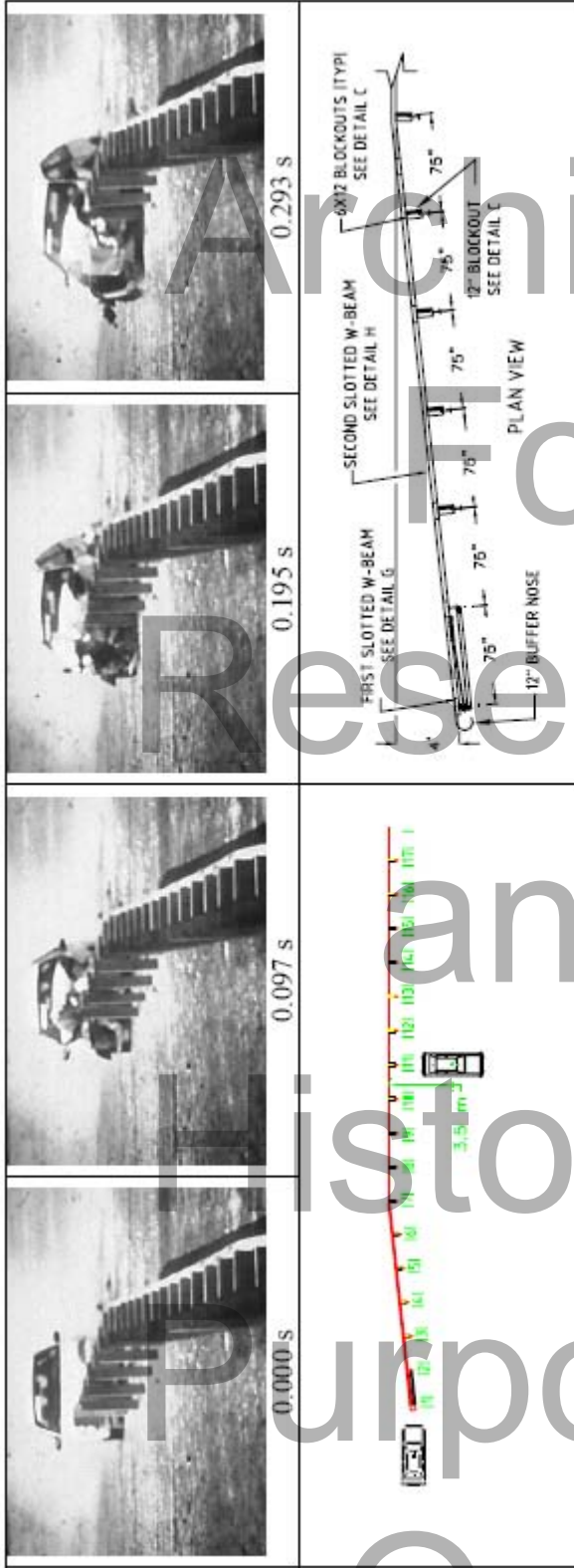

General Information		Impact Conditions		Test Article Deflections (m)	
Test Agency	Texas Transportation Institute	Speed (km/h)	99.9 (62.1 mi/h)	Dynamic	263 (8.63 ft)
Test No.	22054-1-2	Angle (deg)	0.7	Permanent	263 (8.63 ft)
Date	06-15-2005	Exit Conditions		Working Width	7.22 (23.7 ft)
Test Article	Terminal	Speed (km/h)	41.7 (25.9 mi/h)	Vehicle Damage	
Type	SRT-31	Angle (deg)	156	Exterior	
Name	55.2	Occupant Risk Values		VDS	12FR3
Installation Length (m)	Slotted W-beam panels on CRP and	Impact Velocity (m/s)		GDC	12FEW3
Material or Key Elements	SYTP flanged at 4 ft	Longitudinal	7.2 (23.6 ft/s)	Max. Exterior	
	Standard Soil, Dry	Lateral	0.4 (1.3 ft/s)	Vehicle Crush (mm)	430
Soil Type and Condition		THIV (km/h)	26.6	Interior	(16.9 inches)
Test Vehicle		Ridedown Accelerations (g/s)		OCDI	RF0000000
Type	Production	Longitudinal	-9.1	Max. Occupant Compartment	
Designation	820C	Lateral	4.7	Deformation (mm)	18
Model	2000 Chevrolet Geo	PHD (g/s)	9.1	Post-Impact Behavior	(during 2.0 sec after impact)
Mass (kg)		ASI	0.74	Max. Yaw Angle (deg)	-73
Curb	951 (1876 lb)	Max. 0.050-s Average (g/s)		Max. Pitch Angle (deg)	-23
Test Inertial	877 (1933 lb)	Longitudinal	-8.1	Max. Roll Angle (deg)	16
Dummy	79 (175 lb)	Lateral	-2.6		
Gross Static	956 (2108 lb)	Vertical	-3.6		

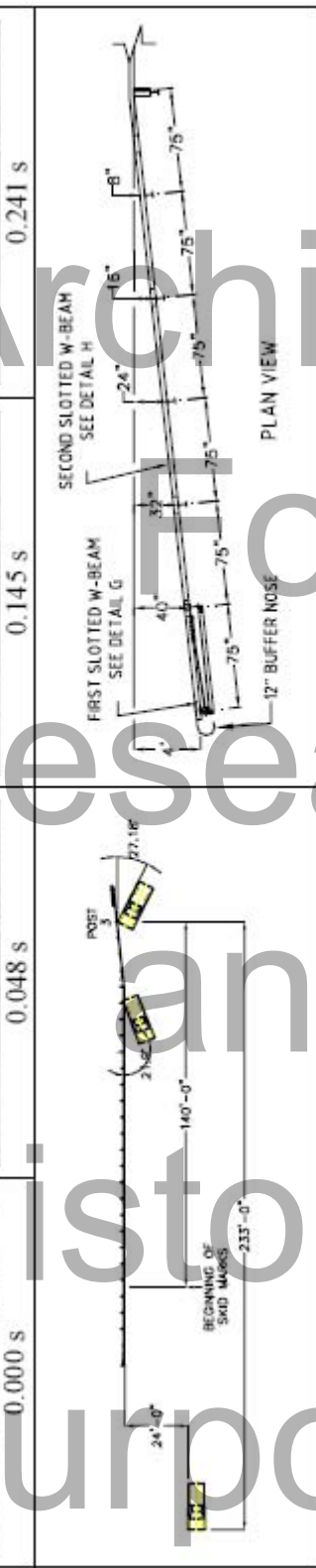
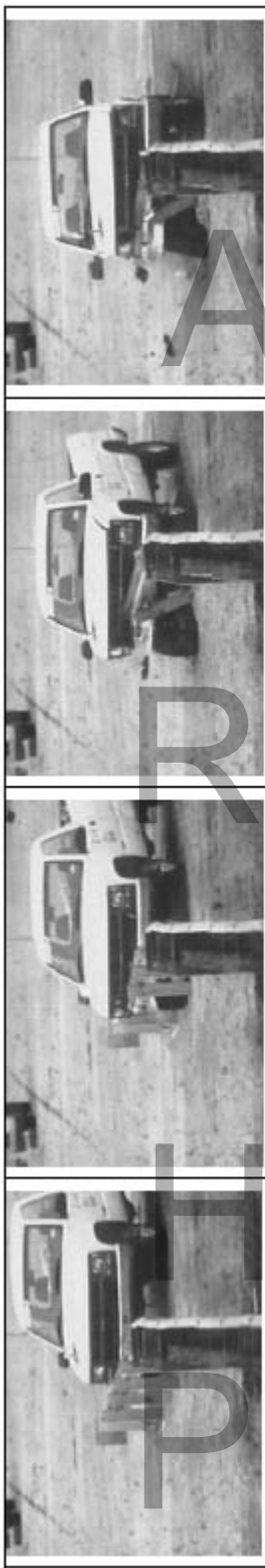

General Information
 Test Agency: Texas Transportation Institute
 Test No: 22054-1-5
 Date: 02-09-2007
Test Article
 Type: Terminal
 Name: SR1-31
 Installation Length (m): 55.2
 Material or Key Elements: Slotted W-beam panels on CRP and SYTP flared at 4 ft
Soil Type and Condition
 Test Vehicle Type: Production
 Designation: 2000P
 Model: 1998 Chevrolet C2500 Pickup
 Mass (kg): 2156
 Curb: 2074
 Test Inertial: No dummy
 Dummy: 2074
 Gross Static: 2074

Impact Conditions
 Speed (km/h): 97.9
 Angle (deg): 27.2
Exit Conditions
 Speed (km/h): 53.9
 Angle (deg): 21.9
Occupant Risk Values
 Impact Velocity (m/s)
 Longitudinal: 4.8
 Lateral: 5.3
 THV (km/h): 27.9
 Ridedown Accelerations (g's)
 Longitudinal: -6.5
 Lateral: 8.1
 PHD (g's): 8.5
 ASI: 0.72
 Max. 0.050-s Average (g's)
 Longitudinal: -4.7
 Lateral: 5.6
 Vertical: -2.4

Test Article Deflections (m)
 Dynamic: 1.19
 Permanent: 1.19
 Working Width: 1.25
Vehicle Damage
 Exterior: xxxxx
 VDS: xxxxxx
 CDC: xxxxxx
 Max. Exterior Vehicle Crush (mm): 370
 Interior: FS0000000
 OCCDI: 0
 Max. Occupant Compartment Deformation (mm): 0

Post-Impact Behavior (during 1.0 sec after impact)
 Max. Yaw Angle (deg): -43
 Max. Pitch Angle (deg): 3
 Max. Roll Angle (deg): -10

Only

Title 23, Code of Federal Regulations

§ 635.411 Material or product selection.

(a) Federal funds shall not participate, directly or indirectly, in payment for any premium or royalty on any patented or proprietary material, specification, or process specifically set forth in the plans and specifications for a project, unless:

(1) Such patented or proprietary item is purchased or obtained through competitive bidding with equally suitable unpatented items; or

(2) The State transportation department certifies either that such patented or proprietary item is essential for synchronization with existing highway facilities, or that no equally suitable alternate exists; or

(3) Such patented or proprietary item is used for research or for a distinctive type of construction on relatively short sections of road for experimental purposes.

(b) When there is available for purchase more than one nonpatented, nonproprietary material, semifinished or finished article or product that will fulfill the requirements for an item of work of a project and these available materials or products are judged to be of satisfactory quality and equally acceptable on the basis of engineering analysis and the anticipated prices for the related item(s) of work are estimated to be approximately the same, the PS&E for the project shall either contain or include by reference the specifications for each such material or product that is considered acceptable for incorporation in the work. If the State transportation department wishes to substitute some other acceptable material or product for the material or product designated by the successful bidder or bid as the lowest alternate, and such substitution results in an increase in costs, there will not be Federal-aid participation in any increase in costs.

(c) A State transportation department may require a specific material or product when there are other acceptable materials and products, when such specific choice is approved by the Division Administrator as being in the public interest. When the Division Administrator's approval is not obtained, the item will be nonparticipating unless bidding procedures are used that establish the unit price of each acceptable alternative. In this case Federal-aid participation will be based on the lowest price so established.

(d) Appendix A sets forth the FHWA requirements regarding (1) the specification of alternative types of culvert pipes, and (2) the number and types of such alternatives which must be set forth in the specifications for various types of drainage installations.

(e) Reference in specifications and on plans to single trade name materials will not be approved on Federal-aid contracts.

(f) In the case of a design-build project, the following requirements apply: Federal funds shall not participate, directly or indirectly, in payment for any premium or royalty on any patented or proprietary material, specification, or process specifically set forth in the Request for Proposals document unless the conditions of paragraph (a) of this section are applicable.

[41 FR 36204, Aug. 27, 1976, as amended at 67 FR 75926, Dec. 10, 2002]